

2.1 WD615发动机/Engine

序号/ No.	名 称 / Designation	页 码 / Page No.
2.1.01	气缸体总成/Cylinder Block Ass	1
2.1.02	气缸体/Cylinder Block	2
2.1.03	飞轮壳及飞轮壳螺栓/Fly Wheel Housing	8
2.1.04	16孔飞轮及飞轮螺栓/Fly wheel and bolts	9
2.1.05	曲轴和飞轮/Crankshaft and Flywheel	10
2.1.06	连杆和活塞/Connecting rod and Piston	11
2.1.07	气缸盖/Cylinder Head	12
2.1.08	吊环夹紧块/Tighten Block	14
2.1.09	配气机构 /Valve-Gear Mechanism	15
2.1.10	发动机前支撑 /Front mounting of engine	17
2.1.11	Φ640环形刚性风扇/Fan	18
2.1.12	中间法兰（装刚性风扇） /Spacer flange	19
2.1.13	水泵和风扇/Water Pump and Fan	20
2.1.14	欧II调温器总成（71度）/Temperature regulator assembly	22
2.1.15	机油泵和机油滤清器/Oil Pump and Oil filter	23
2.1.16	供油系/Fuel Supply System	25
2.1.17	燃油滤清器部分(M+h)/Fuel Filter	29
2.1.18	传感器组(电子式机油压力传传感器) / Sensor	31

2.1.19	2KW交流发电机(多楔带)和减速型起动机/Alternator and Starter	-----	32
2.1.20	增压器回油管/Return Pipe of Supercharger		33
2.1.21	连接弯管/Tube		34
2.1.22	进排气系统(国II增压器中置)/Intake Manifold and Exhaust Manifold	-----	35
2.1.23	废气涡轮增压器/Turbocharger	-----	40
2.1.24	增压器回油管/Return Pipe of Supercharger	-----	41
2.1.25	双缸水冷空压机/Air Compressor	-----	42
2.1.26	油底壳/Oil pan	-----	44

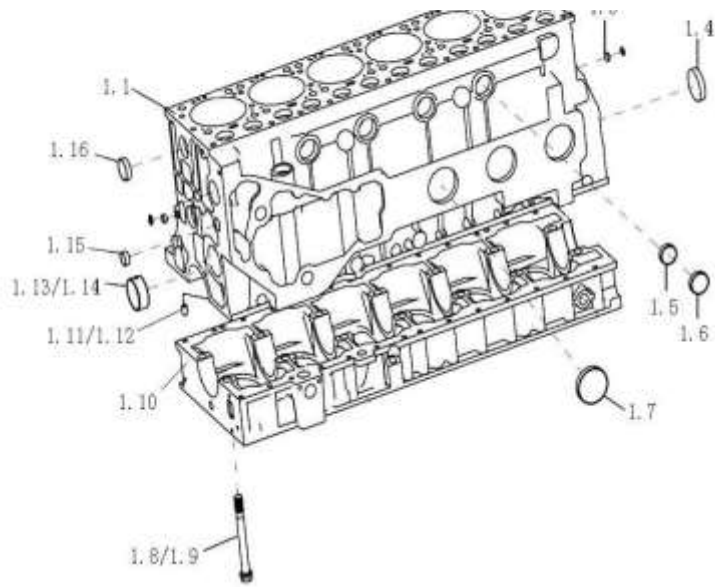

2. 1. 01 气缸总成/CYLINDER BLOCK

序号 No.	零部件图号 Part No.	名称	Part Name	数量 Qty	备注 Remark
1	AZ1095010048	气缸体总成	Cylinder block assembly	1	
1.1	61500010356B	气缸体	Cylinder block	1	
1.2	VG1500010185	气缸盖螺栓	Bolt	21	
1.3	190003989480	碗形塞	Plug	1	
1.4	190003989288	碗形塞	Plug	1	
1.5	190003989289	碗形塞	Plug	4	
1.6	190003989215	碗形塞	Plug	3	
1.7	190003989210	碗形塞	Plug	6	
1.8	VG14010114	主轴承螺栓	Bolt	13	
1.9	VG14010217	主轴承螺栓	Bolt	1	
1.10	161500010366G	曲轴箱	Crankcase	1	
1.11	90003901604A	圆柱销	Pin	2	
1.12	Q5211220	园柱销	Pin	1	
1.13	VG1560010029	凸轮轴衬套	Bushing	5	
1.14	VG1096010010A	凸轮轴衬套	Bushing	1	
1.15	190003989204	碗形塞	Plug	1	
1.16	190003982121	碗形塞	Plug	4	

2.1.02 气缸体/Cylinder Block

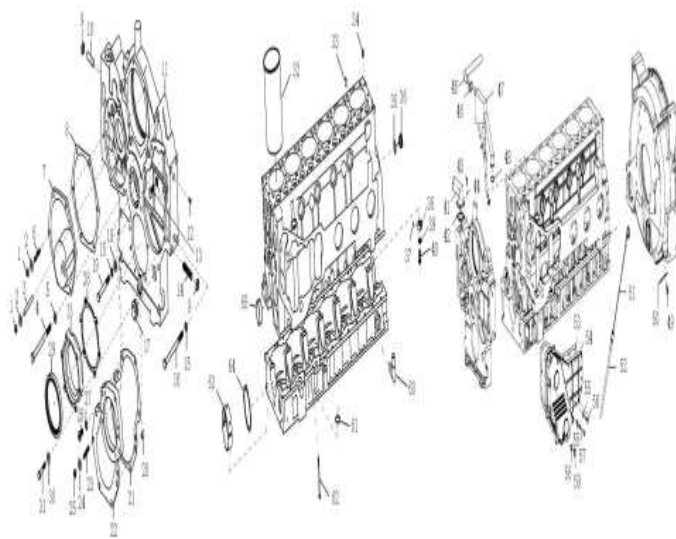

2.1.02 气缸体/Cylinder Block

序号	零部件图号	名称	Part Name	数量	备注
No.	Part No.			Qty	Remark
1	190003871252	1型六角螺母	Nut	6	
2	190003932023	波形弹性垫圈	Wave washer	6	
3	190003813467	双头螺柱	Stud	2	
4	190003802576	六角头螺栓	Bolt	1	
5	190003932024	波形弹性垫圈	Wave washer	1	
6	190003813429	双头螺柱	Stud	3	
7	VG2600010830	空压机齿轮盖	Cover	1	
8	VG14010040	空压机齿轮盖垫片	Gasket	1	
9	190003888453	2型全金属六角锁紧螺母	Nut	8	
10	Q1201245F3	双头螺柱	Stud	2	
11	61557010008A	双缸空压机正时齿轮室	Gear case of dual-cylinder ai	1	
12	190003900085	弹性圆柱销	Pin	4	
13	VG2600010928	前油封座	Base	1	
14	190003813628	双头螺柱	Stud	6	
15	190003931122	弹簧垫圈	Spring washer	10	
16	190003800566	六角头螺栓	Bolt	6	
17	190003962051	轻型六角头园柱螺塞	Plug	1	
18	190003930271	平垫圈	Washer	2	
19	190003800571	六角头螺栓	Bolt	1	
20	190003901507	圆柱销	Pin	4	

2.1.02 气缸体/Cylinder Block

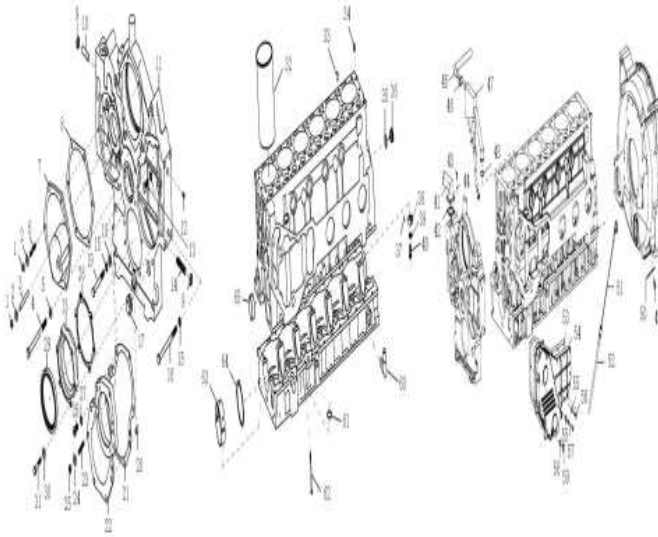

2.1.02 气缸体/Cylinder Block

序号	零部件图号	名称	Part Name	数量	备注
No.	Part No.			Qty	Remark
21	VG14010070	凸轮轴齿轮盖垫片	Gasket	1	
22	VG1500010008A	凸轮轴齿轮盖	Cover	1	
23	190003813443	双头螺柱	Stud	1	
24	190003932023	波形弹性垫圈	Wave washer	6	
25	190003871252	1型六角螺母	Nut	6	
26	190003862524	内六角圆柱头螺钉	Screw	2	
27	190003932025	鞍形弹性垫圈	Washer	2	
28	VG2600010934	前油封座垫片	Gasket	1	
29	VG1047010038	前油封	Oil seal	1	
30	VG9003080001	复合密封垫圈	Gasket	6	
31	190011260039	六角头螺栓	Bolt	6	
32	VG1540010006	气缸套	Cylinder liner	6	
33	190003901604	圆柱销	Pin	6	
34	190003909626	弹性圆柱销	Pin	6	
35	VG2600010735	复合垫圈	Gasket	1	
36	VG1460070011	主油道后螺塞	Plug	1	
37	190003909603	弹性圆柱销	Pin	6	
38	VG2600010659	喷嘴总成	Nozzle assembly	6	
39	VG9003080005	复合密封垫圈	Gasket	6	
40	190003962621	空心螺栓	Hollow bolt	6	

2.1.02 气缸体/Cylinder Block

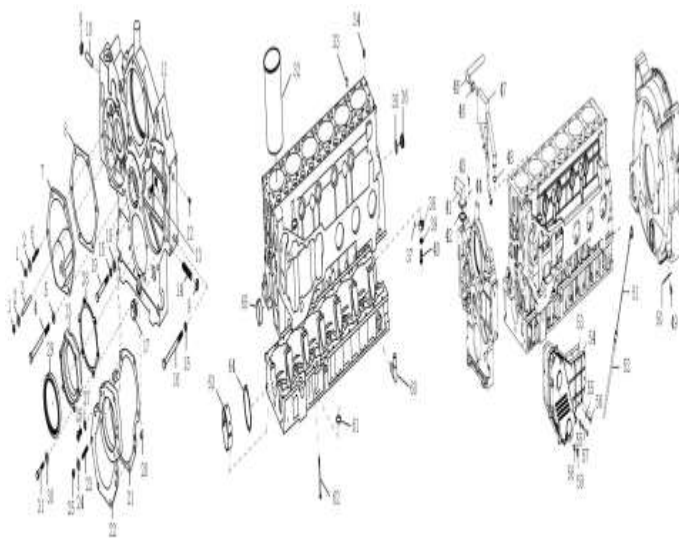

2.1.02 气缸体/Cylinder Block

序号	零部件图号	名称	Part Name	数量	备注
No.	Part No.			Qty	Remark
41	VG1095010040	加油短管组件	Tube assembly	1	
42	VG14010086	加油短管垫片	Gasket	1	
43	190003802321	六角头螺栓	Bolt	4	
44	190003931082	轻型弹簧垫圈	Spring washer	4	
45	VG12G00040038	带纤维夹层的橡胶软管	Hose	1	
46	190003989336	软管卡箍	Hose clamp	2	
47	VG1095010050	油气分离器总成	Oil separator	1	
48	Q734B2650265	O形橡胶密封圈	O-ring	1	
49	190003802511	六角头螺栓	Bolt	2	
50	VG1800210011	观察孔盖	Cover	1	
51	VG1500010600	HOWO用油尺管上组件总成	Dipstick tube components	1	
52	VG2600010705	机油尺管下组件	Dipstick tube components	1	
53	VG1540010015B	机油冷却器盖垫片	cooler shim	1	
54	VG1540010014B	机油冷却器盖	Cover	1	
55	190003932023	波形弹性垫圈	Wave washer	14	
56	190003802437	六角头螺栓	Bolt	7	
57	190003800467	六角头螺栓	Bolt	7	
58	VG9003080005	复合密封垫圈	Gasket	1	
59	190003962020	轻型六角头园柱螺塞	Plug	1	
60	VG2600070097	回油弯管	Hose	1	

2.1.02 气缸体/Cylinder Block

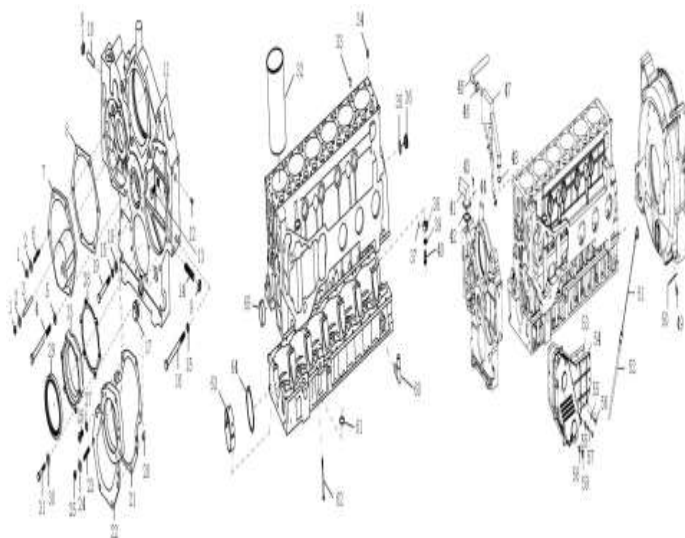

2.1.02 气缸体/Cylinder Block

序号	零部件图号	名称	Part Name	数量	备注
No.	Part No.			Qty	Remark
61	VG1400010032	密封圈	Gasket	2	
62	190003802493	六角头螺栓	Bolt	27	
63	VG1500010046	主轴瓦付	Bushing	7	
64	VG1500010125	止推片付	Shim assembly	2	
65	VG2600010990	凸轮轴衬套	Bushing	1	
66	VG61000010134	密封圈	Gasket	1	
67	VG407010046	密封圈	Gasket	1	
68	VG609E110049	固定板	Plate	1	
69	190003932023	波形弹性垫圈	Wave washer	27	
70	190003802523	六角头螺栓	Bolt	3	
71	VG2600010735	复合垫圈	Gasket	1	
72	190003813429	双头螺柱	Stud	5	
73	190003871252	1型六角螺母	Nut	5	
74	190003932023	波形弹性垫圈	Wave washer	5	
75	190003813429	双头螺柱	Stud	5	
76	VG1540110211	支撑块	Block	2	
77	190003901604	圆柱销	Pin	2	
78	190003931122	弹簧垫圈	Spring washer	12	
79	Q617B18	六角头螺塞	Plug	1	
80	VG9003080007	复合密封垫圈	Gasket	1	

2.1.02 气缸体/Cylinder Block

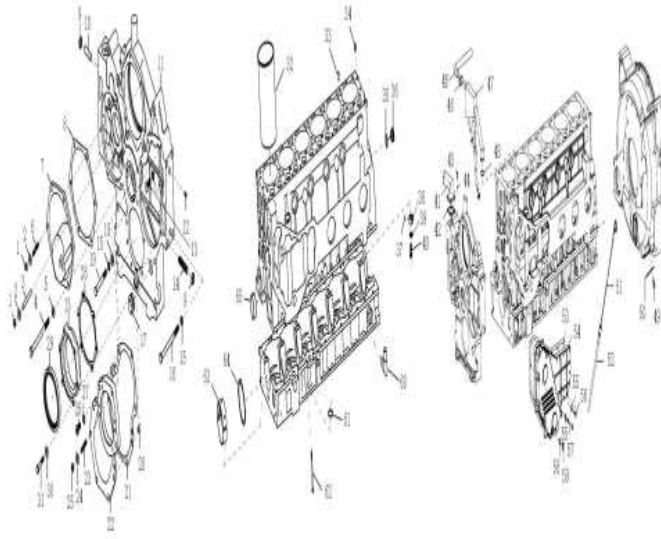

2.1.02 气缸体/Cylinder Block

序号	零部件图号	名称	Part Name	数量	备注
No.	Part No.			Qty	Remark
81	Q218B0820	内六角圆柱头螺钉	Screw	1	
82	VG2600010706	机油尺管	gauge	1	
83	VG2600010707	短管	Tube	1	
84	VG2600010193	铭牌	Name plate	1	
85	90003989301	软管卡箍	Hose clamp	2	
86	VG1095010034	带纤维夹层橡胶软管	Hose	1	
87	VG1500010175	橡胶软管	Hose	1	
88	VG1047010050	后油封总成(迷宫式)	Oil seal	1	
89	VG2600010447	单管夹子	Clip	1	
90	VG2600010446	机油标尺的橡胶软管	Hose	1	
91	190003930261	平垫圈	Washer	1	
92	VG2600010791	标牌铆钉	Rivet	4	
93	VG288730061	O型密封圈	O-ring	1	
94	VG29135	转向泵封口	Cover	1	
95	190003802419	六角头螺栓	Bolt	2	
96	190003932023	波形弹性垫圈	Wave washer	2	
97	190003930261	平垫圈	Washer	1	
98	190003989340	软管卡箍	Hose clamp	1	
99	190003800465	六角头螺栓	Bolt	1	
100	VG1500019089	回油管组件	Return pipe components	1	

2.1.05 曲轴和飞轮/Crankshaft and Flywheel

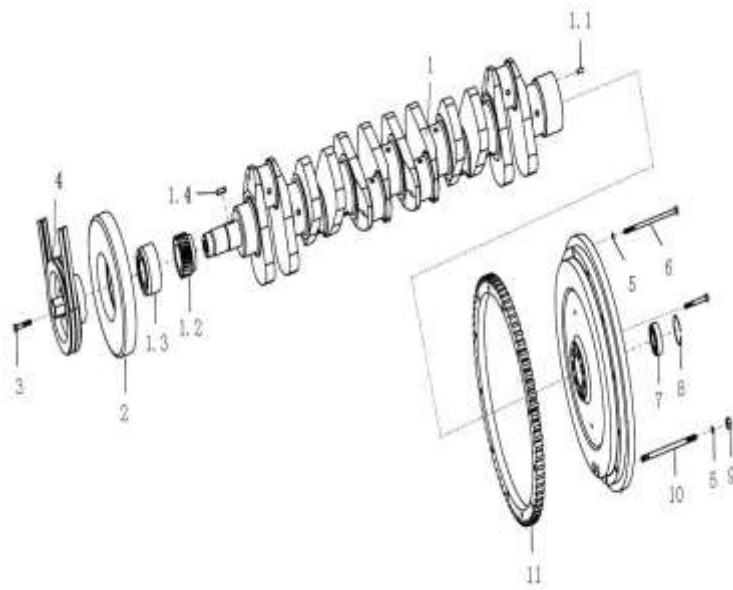

2.1.05 曲轴和飞轮/Crankshaft and Flywheel

序号 No.	零部件图号 Part No.	名称	Part Name	数量 Qty	备注 Remark
1	161560020029	曲轴总成	Crankshaft assembly	1	
1.1	190003901418	圆柱销	Pin	1	
1.2	VG14020038	曲轴齿轮	Crankshaft gear	1	
1.3	VG1500020070	法兰	Flange	1	
1.4	Q5510828	普通平键	Key	1	
1.5	VG2600020311	堵塞	Plug	6	
2	VG1540020003	减振器	Shock absorber	1	
3	190003802558	六角头螺栓	Bolt	8	
4	VG1560020020	皮带轮	Belt pulley	1	
5	190003932024	波形弹性垫圈	Wave washer	12	
6	190003800579	六角头螺栓	Bolt	10	
7	190003311416	球轴承	Ball bearing	1	
8	190003934310	孔用弹性挡圈	Circlip	1	
9	190003871305	1型六角螺母	Nut	2	
10	190003813571	双头螺柱	Stud	2	
11	VG2600020208	飞轮齿圈	Flywheel ring gear	1	

2.1.06 连杆和活塞/Connecting rod and Piston

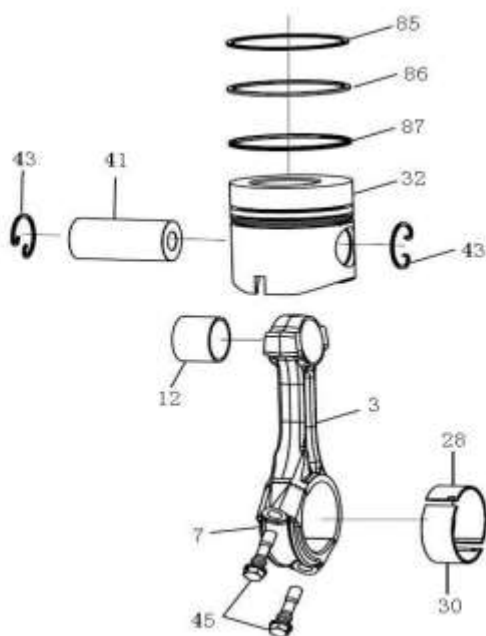

2.1.06 连杆和活塞/Connecting rod and Piston

序号	零部件图号	名称	Part Name	数量	备注
No.	Part No.			Qty	Remark
1	161500030009	连杆总成	Connecting rod assembly	6	
3	161500030008	连杆体	Connecting rod	1	
7	161500030022	连杆盖	Cover	1	
12	VG1500030077	连杆衬套	Bushing	1	
24	VG1500030077	连杆衬套	Bushing	1	
28	VG1560037034	连杆轴瓦上瓦	Bushing	6	
30	VG1560037033	连杆轴瓦下瓦	Bushing	6	
32	VG1560037011	活塞	Piston	6	
36	VG1560030045	油环 (E008)	Oil ring	1	
41	VG1560030013	活塞销	Pin	6	
43	VG1560030012	活塞销挡圈	Circlip	12	
45	VG1500030023	连杆螺栓	Bolt	2	
46	VG1500030023	连杆螺栓	Bolt	2	
53	VG1500030077	连杆衬套	Bushing	1	
54	VG1500030023	连杆螺栓	Bolt	2	
77	VG1560030050	活塞环组	Rings	1	
85	VG1540030007	梯形桶面环	Ring	1	
86	VG1540030006	锥面环	Ring	1	
87	VG1560030045	油环	Oil ring	1	

2.1.07 气缸盖/Cylinder Head

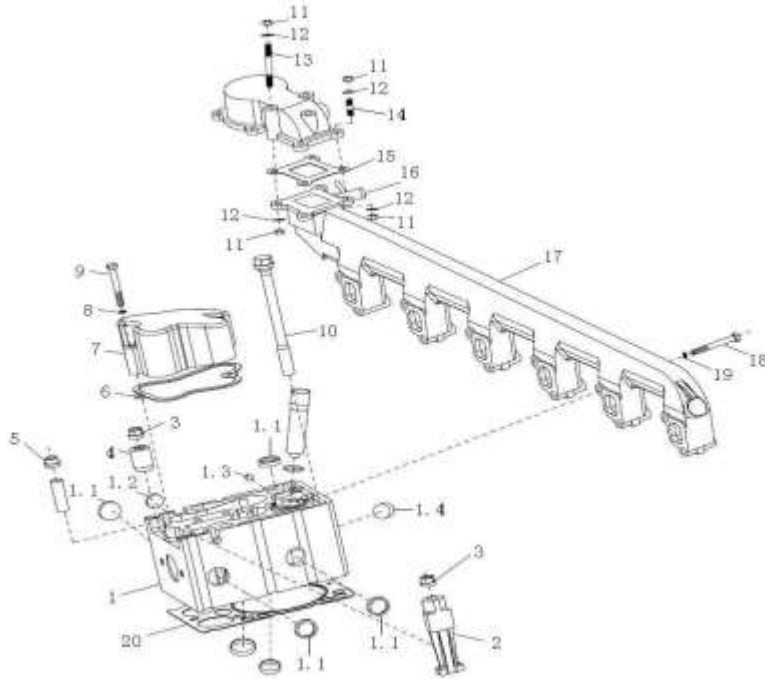

2.1.07 气缸盖/Cylinder Head

序号	零部件图号	名称	Part Name	数量	备注
No.	Part No.			Qty	Remark
1	161560040058	气缸盖总成	Cylinder head assembly	6	
1.1	190003989294	碗形塞片30/8N05564 黄铜	Shim	4	
1.2	190003989721	碗形塞片22/8N05564 黄铜	Shim	1	
1.3	190003989277	碗形塞片12/8N05564 黄铜	Shim	1	
1.4	190003989725	碗形塞片25/8N05564 黄铜	Shim	1	
2	VG1200040027	夹紧块	Block	2	
3	VG1200040034	带肩螺母	Nut	21	
4	VG1200040023A	夹紧块	Block	5	
5	VG1560040032	气门杆密封套	Sleeve	12	
6	VG14040021	气缸盖罩衬垫	Gasket	6	
7	VG14040065	气缸盖罩	Cylinder head cover	6	
8	190003932023	波形弹性垫圈	Wave washer	12	
9	190003800466	六角头螺栓	Bolt	12	
10	VG1500040023	气缸盖主螺栓	Bolt	24	
11	190003871252	1型六角螺母	Nut	4	
12	190014040007	平垫圈	Washer	4	
13	190003813467	双头螺柱	Stud	2	
14	190003813429	双头螺柱	Stud	2	
15	VG1500040106	出水管接管垫片	Gasket	1	
16	VG1500060045	管接头组件	Nozzle assembly	1	

2.1.09 配气机构 /Valve-Gear Mechanism

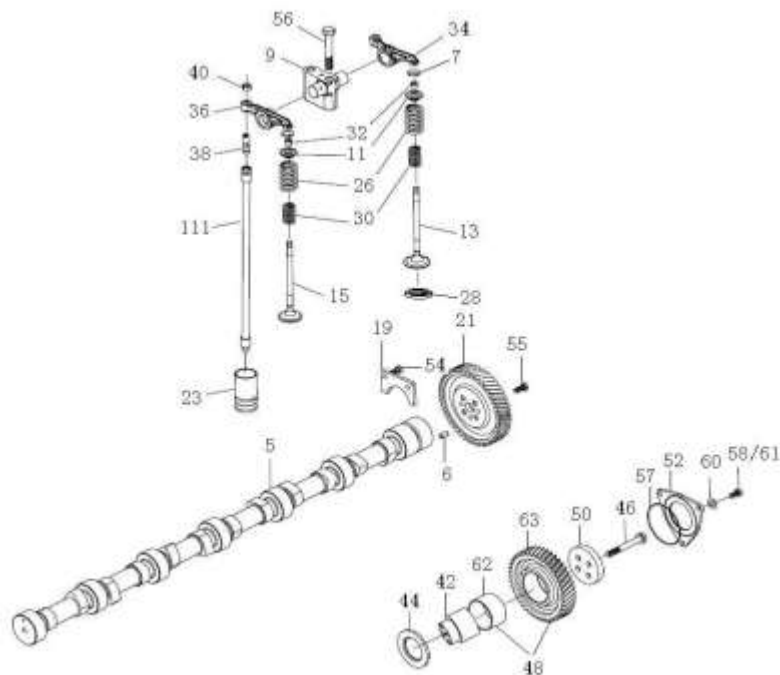

2.1.09 配气机构 /Valve-Gear Mechanism

序号 No.	零部件图号 Part No.	名称	Part Name	数量 Qty	备注 Remark
3	VG1500050097A	凸轮轴总成	Camshaft assembly	1	2014年6月15日后
3	VG1500050097	凸轮轴总成	Camshaft assembly	1	2014年6月15日停
5	VG1500050096A	凸轮轴	Camshaft	1	2014年6月15日后
5	VG1500050096	凸轮轴	Camshaft	1	2014年6月15日停
6	190003901409	圆柱销	Pin	1	
7	VG1500050105	气门帽	Valve cap	12	
9	VG14050119	气门摇臂座	Rocker arm base	6	
11	VG1500050109	气门弹簧上座	Base	12	
13	VG1560051001	进气门	Inlet valve	6	
15	VG1560050041	排气门	Exhaust valve	6	
19	VG14050133	凸轮轴止推片	Shim	1	
21	VG14050053	凸轮轴正时齿轮	Camshaft timing gear	1	
23	VG1500050032	气门挺柱	Valve tappet	12	
26	VG1500050002	气门外弹簧	Valve spring	12	
28	VG14050017	进气门弹簧下座	Spring base	6	
30	VG1500050001	气门内弹簧	Valve spring	12	
32	VG1500050025	气门锁夹	Clip	24	
34	VG14050048	进气门摇臂	Rocker arm	6	
36	VG14050049	排气门摇臂	Rocker arm	6	
38	VG14050010	气门间隙调整螺钉	Screw	12	
40	VG2130050065	气门间隙调整螺母	Nut	12	
42	VG1540059031	中间齿轮轴	Shaft	1	

2.1.09 配气机构 /Valve-Gear Mechanism

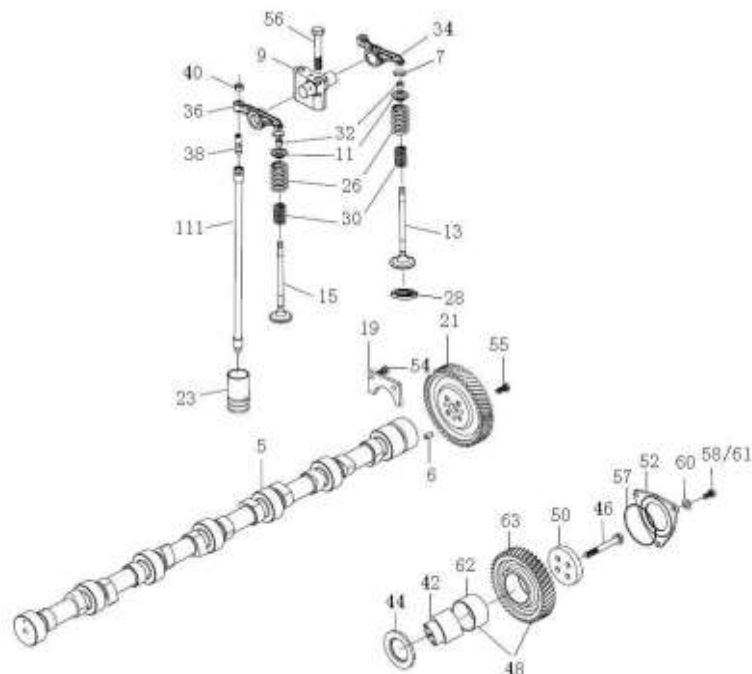

2.1.09 配气机构 /Valve-Gear Mechanism

序号 No.	零部件图号 Part No.	名称	Part Name	数量 Qty	备注 Remark
44	VG1540059032	中间齿轮垫片	Gasket	1	
46	VG1560050059	六角头螺栓	Bolt	4	
48	VG1560050053	中间齿轮总成(参图16156)	Gear assembly	1	
50	VG1560050045	挡板	Plate	1	
52	VG1560050046A	盖板	Cover	1	
54	190003802399	六角头螺栓	Bolt	2	
55	190003802443	六角头螺栓	Bolt	4	
56	190003802655	六角头螺栓	Bolt	12	
57	190003120602	密封圈	Gasket	1	
58	190003813414	双头螺柱	Stud	2	
59	190003871252	1型六角螺母	Nut	2	
60	190003932023	波形弹性垫圈	Wave washer	3	
61	190003862419	内六角圆柱头螺钉	Screw	1	
62	VG1560050054	衬套	Bushing	1	
63	VG1560050052	中间齿轮	Gear	1	
111	VG1092050020	气门推杆总成	Push rod assembly	12	
113	VG1092050019	气门推杆杆身	Rod	1	
114	VG1096050031	气门推杆凹头	Head	1	
115	VG1096050033	气门推杆球头	Ball joint	1	

2.1.13 水泵和风扇/ water Pump and Fan

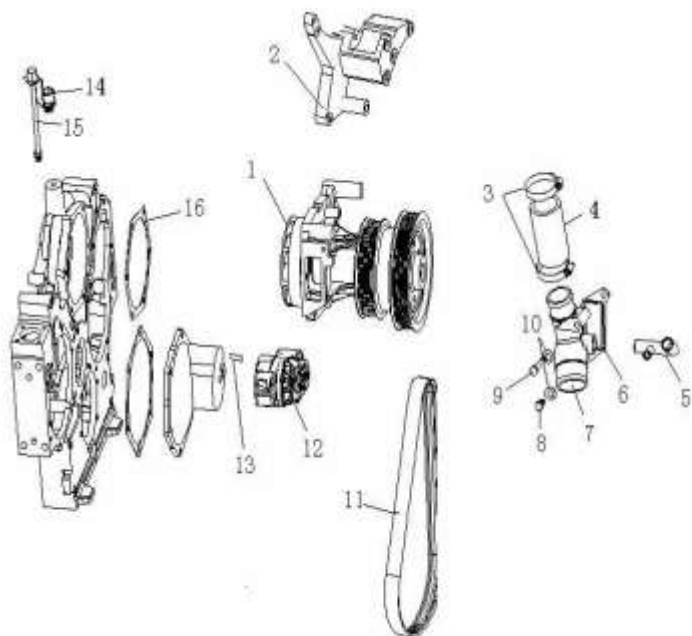

2.1.13 水泵和风扇/ water Pump and Fan

序号 No.	零部件图号 Part No.	名称	Part Name	数量 Qty	备注 Remark
1	VG1500060051	水泵总成	Water pump assembly	1	
2	VG1500130018A	空调托架	Bracket	1	
3	Q150B1075TF2	六角头螺栓	Bolt	1	
4	VG61000060276	胶管	Hose	1	
5	VG1560060004	回水管接头组件	Nozzle assembly	1	
6	VG14060024	水管接头垫片	Gasket	1	
7	VG1560060023	水管接头	Nozzle	1	
8	190003802424	六角头螺栓	Bolt	1	
9	190003800467	六角头螺栓	Bolt	1	
10	190003932023	波形弹性垫圈	Wave washer	2	
11	VG1069020010	汽车多楔带	Belt	1	
12	VG2600060313	自动张紧轮	Tensioner	1	
13	Q5211022	圆柱销	Pin	1	
14	Q150B1625	六角头螺栓	Bolt	1	
15	VG2600060460	水泵加黄油装置	Grease nipple	1	
16	VG140608	水泵密封垫	Gasket	1	
17	190003802424	六角头螺栓	Bolt	6	
18	190003888451	2型全金属六角锁紧螺母	Nut	6	
19	190003989308	软管卡箍	Hose clamp	2	
20	190003802432	六角头螺栓	Bolt	1	

2.1.15 机油泵和机油滤清器/Oil Pump and Oil filter

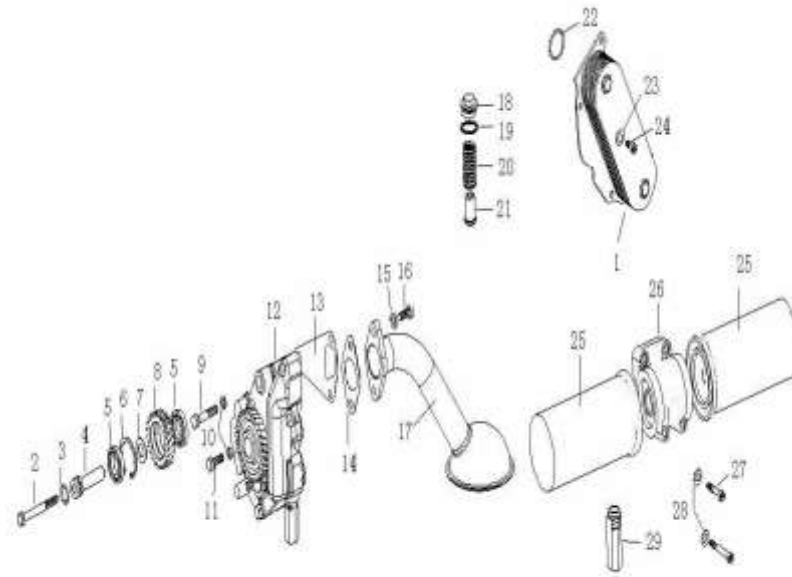

2.1.15 机油泵和机油滤清器/Oil Pump and Oil filter

序号 No.	零部件图号 Part No.	名称	Part Name	数量 Qty	备注 Remark
1	VG1500010334	机油冷却器(8片)	Oil cooler	1	
2	190003802578	六角头螺栓	Bolt	1	
3	VG14070155	密封圈	Gasket	1	
4	VG14070056	中间齿轮轴	Shaft	1	
5	190003311410	向心球轴承	Ball bearing	2	
6	190003934732	带凸齿的孔用挡圈	Circlip	1	
7	VG14070049	中间隔圈	Spacer	1	
8	VG14070061	机油泵中间齿轮	Gear	1	
9	190003800551	六角头螺栓	Bolt	1	
10	190003931122	弹簧垫圈	Spring washer	2	
11	190003802527	六角头螺栓	Bolt	1	
12	VG1500070021	45mm加宽机油泵	Oil pump	1	
13	VG14070055	机油泵垫片	Gasket	1	
14	VG140778	垫片	Shim	1	
15	190003932025	鞍形弹性垫圈	Washer	2	
16	190003802523	六角头螺栓	Bolt	2	
17	VG1800070054	集滤器总成	Oil filter assembly	1	
18	190003962051	轻型六角头园柱螺塞	Plug	1	
19	VG2600010735	复合垫圈	Gasket	1	
20	VG14070068	安全阀弹簧	Spring	1	

2.1.16 供油系/Fuel Supply System

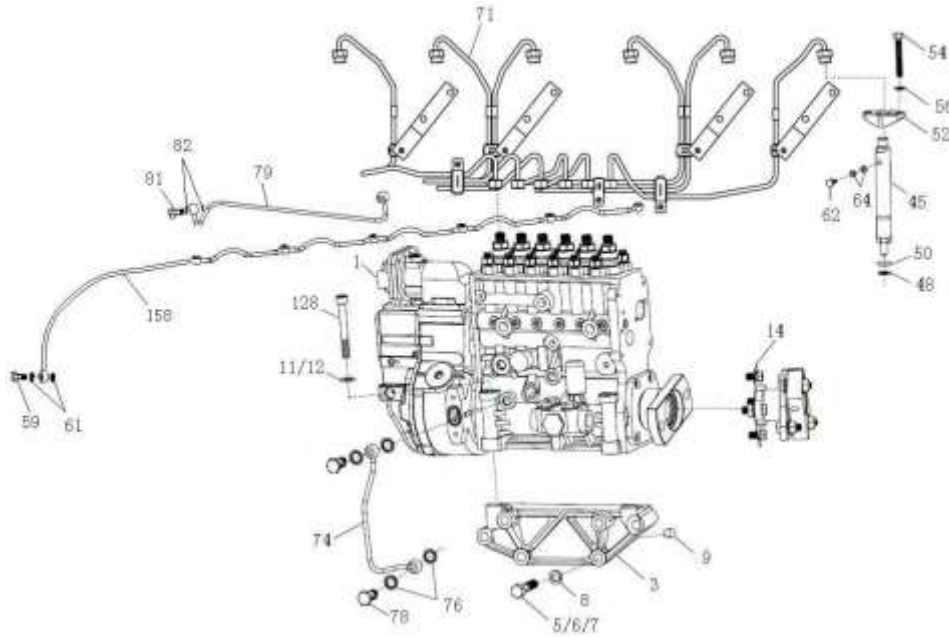

2.1.16 供油系/Fuel Supply System

序号	零部件图号	名称	Part Name	数量	备注
No.	Part No.			Qty	Remark
1	VG1560080023	喷油泵带K型调速器	Fuel injection pump assembly	1	
3	VG1500080174	喷油泵托架	Bracket	1	
5	Q150B1295	六角头螺栓	Bolt	3	
6	Q150B1285	六角头螺栓	Bolt	1	
7	Q150B1245	六角头螺栓	Bolt	2	
8	190003931142	弹簧垫圈	Spring washer	6	
9	190003901600	圆柱销	Pin	2	
11	190003930271	平垫圈	Washer	4	
12	VG18872339	自锁垫圈	Washer	4	
14	VG1560080300	联轴器总成	Coupling assembly	1	
16	VG1560080279	联轴器法兰组件	Flange components	1	
17	VG1560080266	法兰	Flange	2	
18	VG1560080270	连接管	Connecting pipe	1	
19	VG1560080219	弹性连接片	Spring piece	12	
20	VG1560080273	衬套	Bushing	8	
21	Q40012T16F9	小垫圈	Washer	8	
22	VG1560080271	垫圈	Washer	8	
23	Q150B1250TF2	六角头螺栓	Bolt	2	
24	Q150B1235TF2	六角头螺栓	Bolt	4	
25	Q150B1240TF2	六角头螺栓	Bolt	2	

2.1.16 供油系/Fuel Supply System

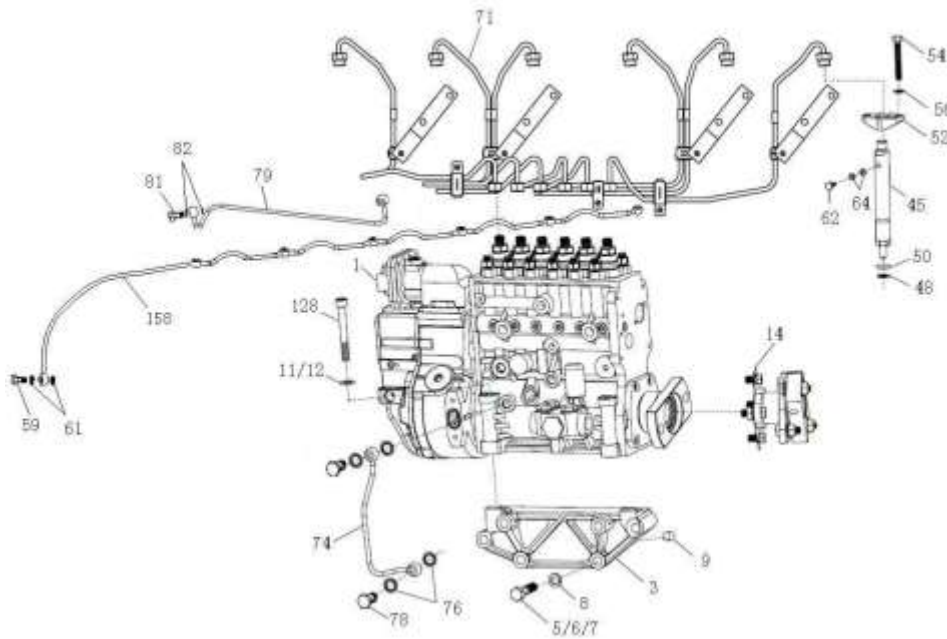

2.1.16 供油系/Fuel Supply System

序号	零部件图号	名称	Part Name	数量	备注
No.	Part No.			Qty	Remark
26	Q340B12T13F2	1型六角螺母	Nut	8	
27	VG1560080194	角度调节板	Plate	1	
28	VG1560080001	六角头螺栓	Bolt	1	
45	VG1560080276	喷油器总成	Fuel injector	6	
48	VG14080082	垫圈	Washer	6	
50	VG609070080	密封垫圈	Gasket	6	
52	VG1500080094A	紧固压板	Plate	6	
54	VG2600080383	六角头螺栓	Bolt	12	
56	190003932023	波形弹性垫圈	Wave washer	12	
59	VG1500080090	空心螺栓	Hollow bolt	6	
61	VG9003080001	复合密封垫圈	Gasket	12	
66	190003171697	塑料紧箍带	Cable binder	2	
67	190003171356	塑料紧固带A5*280	Cable binder	2	
71	VG1560080278A	高压油管组	Injection tube assembly	1	
73	VG1560080172	支承架	Bracket	1	
74	VG1560070025	润滑油回油管总成	Tube assembly	1	
76	VG2600080200	密封垫圈	Gasket	2	
78	190003962621	空心螺栓	Hollow bolt	1	
79	VG1560080284	空气管	Tube	1	
81	190003962612	空心螺栓	Hollow bolt	1	

2.1.16 供油系/Fuel Supply System

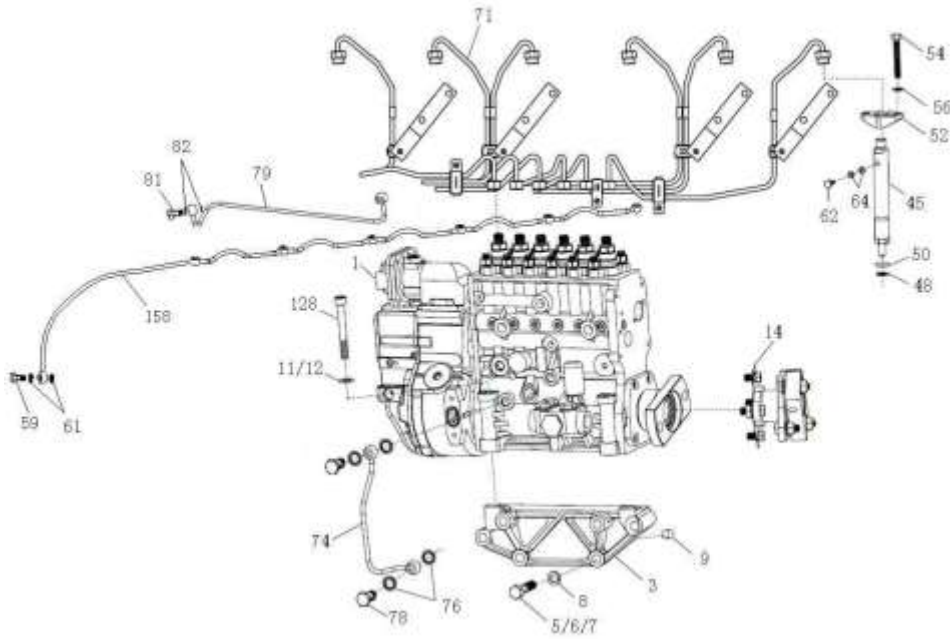

2.1.16 供油系/Fuel Supply System

序号	零部件图号	名称	Part Name	数量	备注
No.	Part No.			Qty	Remark
82	VG9003080004	复合密封垫圈	Gasket	2	
112	VG1560080172	支承架	Bracket	1	
119	VG1095088010	输油泵总成	Fuel pump	1	
120	VG1095088015	溢油阀总成	Valve	1	
121	VG1095088019	修理包	Repair bag	1	
122	VG1095088021	油封	Oil seal	1	
123	VG1095088022	出油阀紧座	Delivery valve base	1	
124	VG1095088024	烟限器总成	Smoke limiter	1	
125	VG1095088026	调盖总成	Cover	1	
126	VG1095088028	调速器壳体	Housing	1	
127	VG1095088030	飞块及支架总成	Flyweight and bracket assembly	1	
128	190003800571	六角头螺栓	Bolt	4	
130	VG1560080279	联轴器法兰组件	Flange components	1	
131	VG1560080219	弹性连接片	Spring piece	12	
132	VG1560080273	衬套	Bushing	8	
133	Q40012T16F9	小垫圈	Washer	8	
134	VG1560080271	垫圈	Washer	8	
135	Q150B1250TF2	六角头螺栓	Bolt	2	
136	Q150B1235TF2	六角头螺栓	Bolt	4	
137	Q150B1240TF2	六角头螺栓	Bolt	2	

2.1.16 供油系/Fuel Supply System

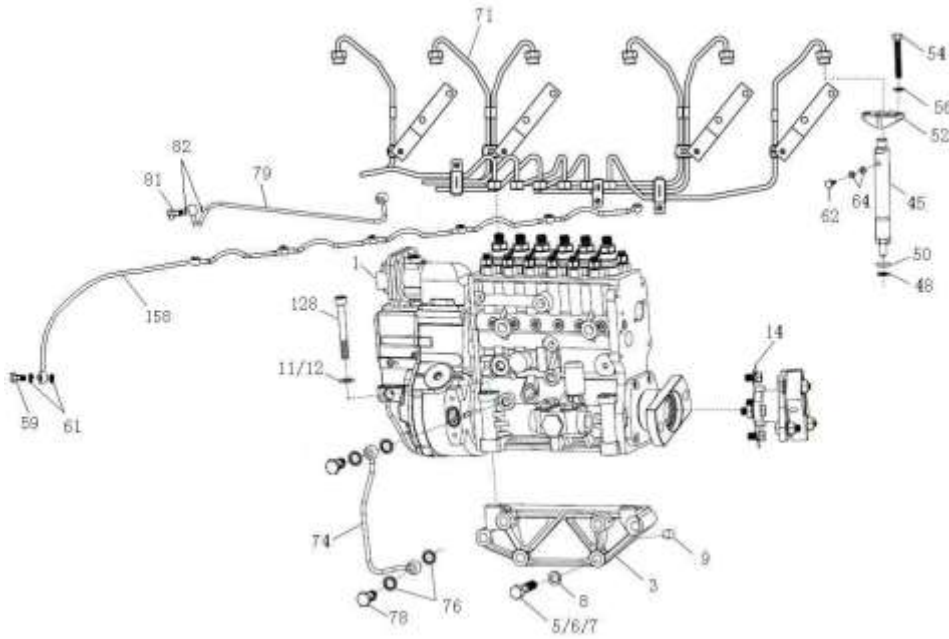

2.1.16 供油系/Fuel Supply System

序号	零部件图号	名称	Part Name	数量	备注
No.	Part No.			Qty	Remark
138	Q340B12T13F2	1型六角螺母	Nut	8	
139	VG1560080194	角度调节板	Plate	1	
140	VG1560080001	六角头螺栓	Bolt	1	
142	VG1560080279	联轴器法兰组件	Flange components	1	
143	VG1560080219	弹性连接片	Spring piece	12	
144	VG1560080273	衬套	Bushing	8	
145	Q40012T16F9	小垫圈	Washer	8	
146	VG1560080271	垫圈	Washer	8	
147	Q150B1250TF2	六角头螺栓	Bolt	2	
148	Q150B1235TF2	六角头螺栓	Bolt	4	
149	Q150B1240TF2	六角头螺栓	Bolt	2	
150	Q340B12T13F2	1型六角螺母	Nut	8	
151	VG1560080194	角度调节板	Plate	1	
152	VG1560080001	六角头螺栓	Bolt	1	
153	VG1095088005	油嘴	Nozzle	1	
154	VG1095088002	柱塞偶件	Plunger assembly	1	
155	VG1095088004	出油阀偶件	Delivery valve assembly	1	
158	VG1500080095A	回油管总成	Tube assembly	1	

2.1.17 燃油滤清器部分 (M+h)/Fuel Filter

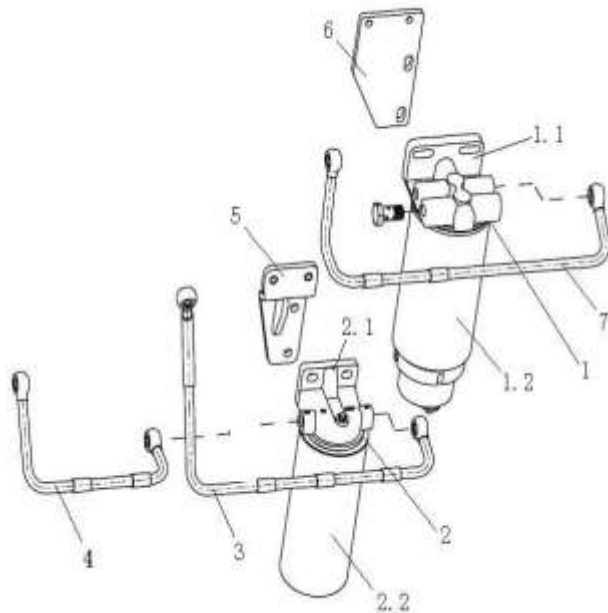

2.1.17 燃油滤清器部分 (M+h)/Fuel Filter

序号	零部件图号	名称	Part Name	数量	备注
No.	Part No.			Qty	Remark
1	VG1560080016	旋装式燃油粗滤器总成	Fuel primary filter assembly	1	
1.1	VG1560080014	旋装式燃油粗滤器滤座	Base	1	
1.2	VG1047080011	滤芯和滤杯总成	Filter and cup assembly	1	
1.2.1	VG1540080311	旋装式燃油粗滤器	Fuel primary filter	1	
1.2.2	VG1047080009	燃油粗滤器水杯	Fuel coarse filte cup	1	
2	VG1560080011	旋装式燃油精滤器总成	Fuel fine filter assembly	1	
2.1	VG1560080013	旋装式燃油精滤器滤座	Base	1	
2.2	VG1560080012	旋装式燃油精滤器	Fuel fine filter assembly	1	
3	VG1092080017	燃油管总成	Fuel Tube	1	
4	VG1092080018	燃油管总成	Fuel Tube	1	
5	VG1092080026	燃油精滤器托架	Bracket	1	
6	VG1540080027	粗滤支架	Bracket	1	
7	VG1092080019	燃油管总成	Fuel Tube	1	
8	190003802527	六角头螺栓	Bolt	2	
9	190003931122	弹簧垫圈	Spring washer	2	
10	190003935009	平垫圈	Washer	2	
11	190003802523	六角头螺栓	Bolt	2	
12	190003932024	波形弹性垫圈	Wave washer	2	
13	190003930012	大垫圈	Washer	2	
14	VG2600080200	密封垫圈	Gasket	4	

2.1.18 传感器组(电子式机油压力传感器) / Sensor

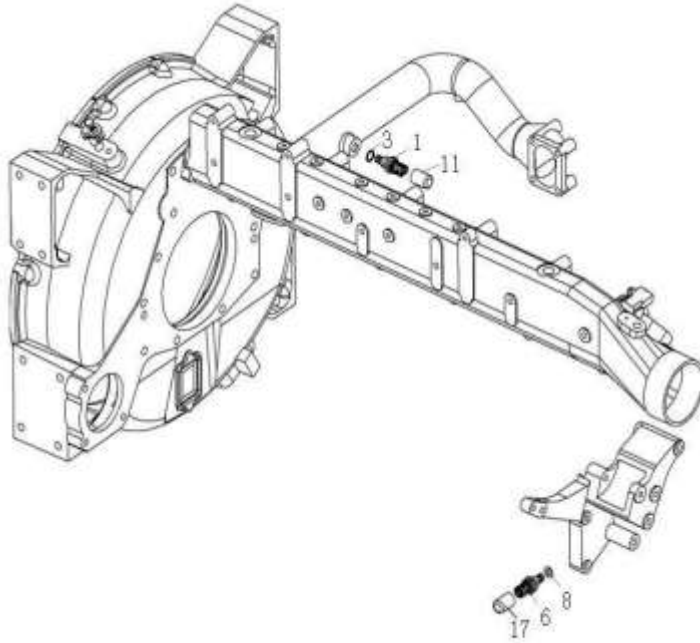

2.1.18 传感器组(电子式机油压力传感器) / Sensor

序号	零部件图号	名称	Part Name	数量	备注
No.	Part No.			Qty	Remark
1	VG1500090061	水温表传感器	Water temperature sensor	1	
3	VG9003080005	复合密封垫圈	Gasket	1	
6	VG1092090311	电子机油压力传感器	Oil pressure sensor	1	
8	VG2600080275	复合密封垫圈	Gasket	1	
11	VG2600090318	水温传感器罩	Cover	1	
17	VG1095090139	机油压力传感器罩	Cover	1	
2	VG1500090061	水温表传感器	Water temperature sensor	1	
4	VG9003080005	复合密封垫圈	Gasket	1	
5	VG9003080005	复合密封垫圈	Gasket	1	
7	VG1092090311	电子式机油压力传感器	Oil pressure sensor	1	
9	VG2600080275	复合密封垫圈	Gasket	1	
10	VG2600080275	复合密封垫圈	Gasket	1	
12	VG2600090318	水温传感器罩	Water temperature sensor	1	
13	VG2600090318	水温传感器罩	Water temperature sensor	1	
18	VG1095090139	机油压力传感器罩	Cover	1	
19	VG1095090139	机油压力传感器罩	Cover	1	

2.1.19 2KW交流发电机(多楔带)和减速型起动机(HW和A7专用)/Alternator and Starter

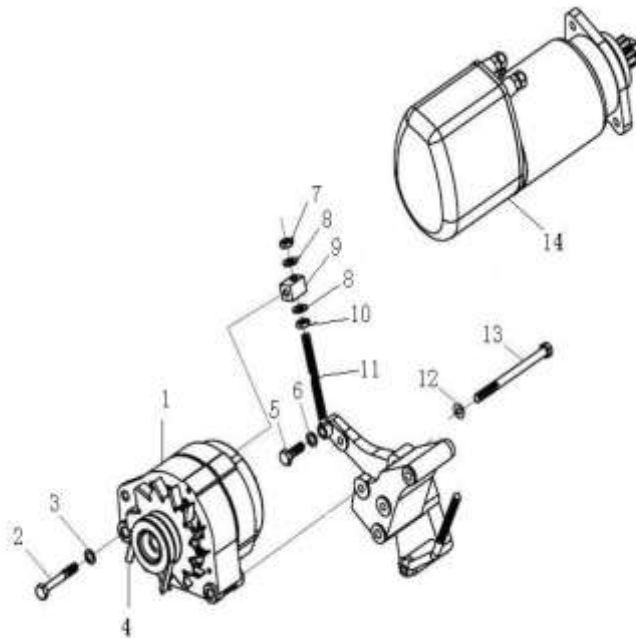

2.1.19 2KW交流发电机(多楔带)和减速型起动机/Alternator and Starter

序号 No.	零部件图号 Part No.	名称	Part Name	数量 Qty	备注 Remark
1	VG1560090012	1540W交流发电机	Alternator-1540W	1	
2	VG1062060004	发电机双头螺栓	Stud	1	
3	190003932025	鞍形弹性垫圈	Washer	1	
4	VG1500090070	汽车多楔带	Belt	1	
5	190003802527	六角头螺栓	Bolt	1	
6	190003930271	平垫圈	Washer	1	
7	190003888452	2型全金属六角锁紧螺母	Nut	1	
8	190003935125	平垫圈	Washer	2	
9	VG1500090027	拉紧块	Block	1	
10	190003871305	1型六角螺母	Nut	1	
11	VG1500090039	拉紧螺栓(参图1413C 090)	Bolt	1	
12	190003932025	鞍形弹性垫圈	Washer	1	
13	190003800568	六角头螺栓	Bolt	1	
14	VG1560090007	起动机	Starter	1	
15	VG2600090288	压紧块	Block	1	
16	190003813532	双头螺柱	Stud	3	
17	190003888452	2型全金属六角锁紧螺母	Nut	3	

2.1.22 进排气系统/ Intake and Exhaust Manifold

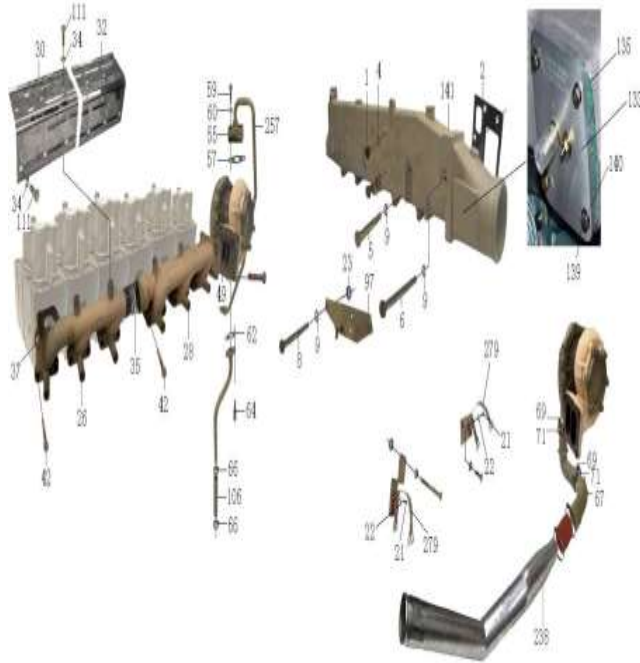

2.1.22 进排气系统/ Intake and Exhaust Manifold

序号 No.	零部件图号 Part No.	名称	Part Name	数量 Qty	备注 Remark
1	190003962014	六角头螺塞	Plug	1	
2	VG1500110024	进气管垫片	Gasket	6	
4	VG9003080003	复合密封垫圈	Gasket	1	
5	190003800465	六角头螺栓	Bolt	6	
6	VG14110064	进气管紧固螺栓	Bolt	4	
8	190003800497	六角头螺栓	Bolt	2	
9	190003932023	波形弹性垫圈	Wave washer	12	
21	190003802411	六角头螺栓	Bolt	2	
22	190003932023	波形弹性垫圈	Wave washer	2	
23	VG609E110036	调整垫圈	Washer	6	
25	190003932023	波形弹性垫圈	Wave washer	2	
26	VG2600111137	前排气歧管	Exhaust manifold	1	
28	VG2600111136	后排气歧管	Exhaust manifold	1	
30	VG2600111142	前隔热罩	Cover	1	
32	VG2600111143	后隔热罩	Cover	1	
34	190003937282	大垫圈	Washer	12	
35	VG260110162	排气管密封环	Seal ring	4	
37	VG1560110111	排气管垫片	Gasket	6	
42	VG2600111052	排气管紧固螺栓	Bolt	12	
46	190003888470	自锁螺母	Nut	4	

2.1.22 进排气管/ Intake and Exhaust manifold

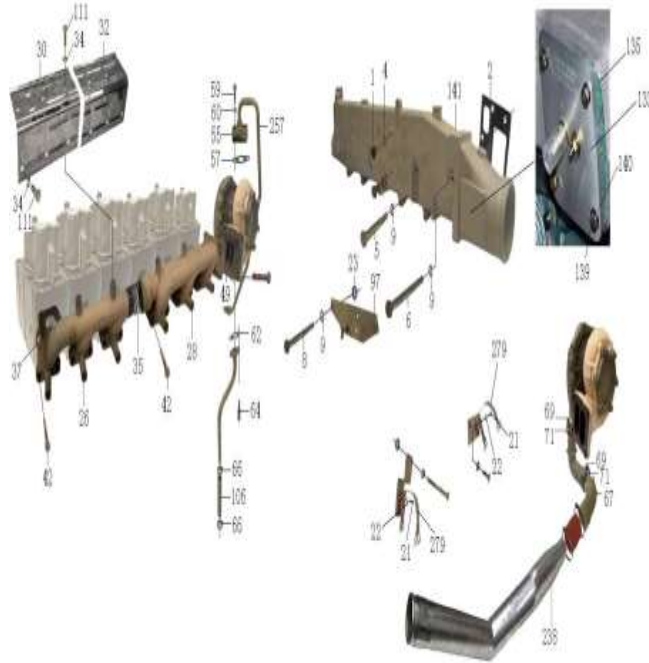

2.1.22 进排气管/ Intake and Exhaust manifold

序号 No.	零部件图号 Part No.	名称	Part Name	数量 Qty	备注 Remark
49	VG1560110210	增压器密封垫	Gasket	1	
55	VG1560110152	进油管法兰	Flange	1	
57	VG609E110050	进油管垫片	Gasket	1	
59	190003862428	内六角圆柱头螺钉	Screw	2	
60	VG188250083	自锁垫圈	Washer	4	
62	VG2600110048	回油管法兰垫片	Gasket	1	
64	VG1460070014	回油管螺栓	Bolt	2	
66	190003989340	软管卡箍	Hose clamp	2	
67	VG1800110045	连接弯管	Tube	1	
69	VG1560110226	夹子	Clip	2	
71	VG190320035	密封圈	Gasket	2	
93	190003932023	波形弹性垫圈	Wave washer	2	
94	190003802419	六角头螺栓	Bolt	4	
95	190003802415	六角头螺栓	Bolt	2	
96	190003932023	波形弹性垫圈	Wave washer	6	
97	VG9100570019	悬臂总成	Bracket ass.	1	
99	VG9100570018	悬臂	Bracket	1	
100	VG9100570017	弯板	Plate	1	
101	VG9000570035	轴销	Pin	1	
106	VG2600070071	增压器回油用软管	Hose	1	

2.1.22 进排气系统/ Intake and Exhaust Manifold

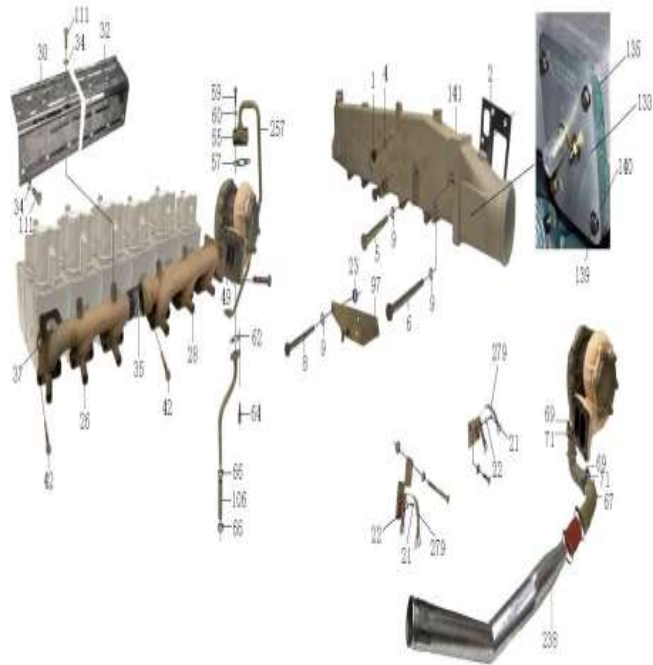

2.1.22 进排气系统/ Intake and Exhaust Manifold

序号 No.	零部件图号 Part No.	名称	Part Name	数量 Qty	备注 Remark
111	VG1500110963	耐热螺栓	Bolt	12	
113	VG2600110668	增压器排气口堵盖	Plug	1	
117	VG2600111429	双头螺柱M10X48 DIN939	Double end studs	4	
119	190003802411	六角头螺栓	Bolt	2	
133	VG2600110458	进气管盖板	Plate	1	
135	VG2600110457	进气管盖板垫片	Gasket	1	
139	190003802331	六角头螺栓	Bolt	4	
140	190003932008	波形弹性垫圈B6	Spring washer	4	
141	VG2600110812	进气管总成	Intake manifold	1	
143	VG2600110688	进气管	Intake manifold	1	
144	VG2600110455	盖板	Cover	1	
146	VG2600110456	垫片	Shim	1	
148	190003931102	弹簧垫圈	Spring washer	3	
149	190003802432	六角头螺栓	Bolt	3	
151	VG2600110688	进气管	Intake manifold	1	
152	VG2600110455	盖板	Cover	1	
154	VG2600110456	垫片	Shim	1	
156	190003931102	弹簧垫圈	Spring washer	3	
157	190003802432	六角头螺栓	Bolt	3	
188	VG9003980003	强力卡箍	Clamp	2	

2.1.22 进排气管/ Intake and Exhaust Manifold

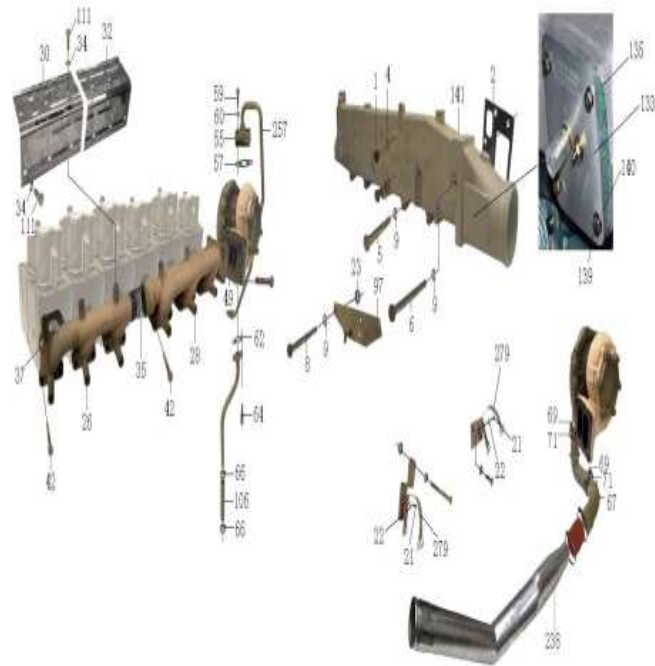

2.1.22 进排气管/ Intake and Exhaust Manifold

序号 No.	零部件图号 Part No.	名称	Part Name	数量 Qty	备注 Remark
202	VG9100570018	悬臂	Bracket	1	
203	VG9100570017	弯板	Plate	1	
204	VG9000570035	轴销	Pin	1	
206	VG9100570018	悬臂	Bracket	1	
207	VG9100570017	弯板	Plate	1	
208	VG9000570035	轴销	Pin	1	
209	VG29108B	堵盖	Cover	2	
211	VG29129A	堵盖	Cover	1	
218	VG29130A	堵盖	Cover	1	
227	VG1034110100	卡箍	Clamp	1	
229	Q150B0855	六角头螺栓	Bolt	1	
230	Q33408	1型全金属六角锁紧螺母	Nut	1	
231	Q40108	平垫圈	Washer	1	
232	Q40308	弹簧垫圈	Spring washer	1	
238	VG1047110104	中冷管	Tube	1	
242	VG1047110103	硅胶管	Hose	1	
246	VG1047110102	支架	Bracket	1	
253	VG1047110105	固定板	Plate	1	
257	VG1092110043	增压器进油管总成	Tube assembly	1	
260	190003559563	卡套	Ring	2	

2.1.25 双缸水冷空压机/Air Compressor

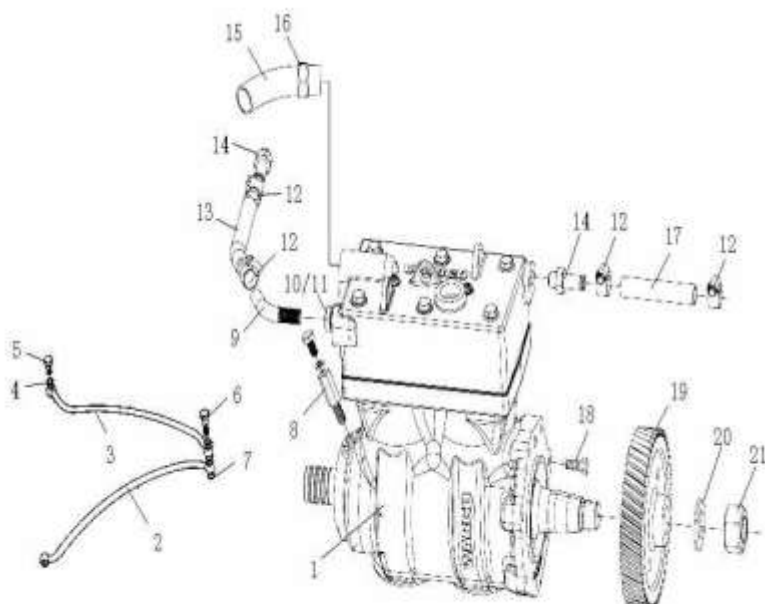

2.1.25 双缸水冷空压机/Air Compressor

序号	零部件图号	名称	Part Name	数量	备注
No.	Part No.			Qty	Remark
1	VG1093130001	双缸水冷空压机	Air compressor	1	
2	VG1560070060	高压油泵润滑油管总成	Tube assembly	1	
3	VG1560070050	空压机润滑油管总成	Tube assembly	1	
4	VG9003080003	复合密封垫圈	Gasket	2	
5	190003962607	空心螺栓	Hollow bolt	1	
6	VG1560070012	空心螺栓	Hollow bolt	1	
7	VG9003080003	复合密封垫圈	Gasket	3	
8	VG1560070051	过渡接头	Nozzle	2	
9	VG1560060012	空压机进水管接头	Nozzle	1	
10	VG2600080200	密封垫圈	Gasket	1	
11	Q351B14	六角薄螺母	Nut	1	
12	190003989336	软管卡箍	Hose clamp	4	
13	VG1560060019	国II空压机进水管	Hose	1	
14	VG2600130026	水冷空压机水管接头	Nozzle	2	
15	VG1560130035	空压机进气管接头	Nozzle	1	
16	190003559778	六角螺母	Nut	1	
17	VG1560060018	空压机出水管	Hose	1	
18	Q1860830TF2	六角法兰面螺栓	Bolt	7	
19	VG1560130064	喷油泵齿轮	Gear	1	
20	VG409020045	垫片	Shim	1	

